

QV 900

USER MANUAL



**Tools for Physiologically Relevant *in vitro*
Cell Culture**

Issue Number 2.0



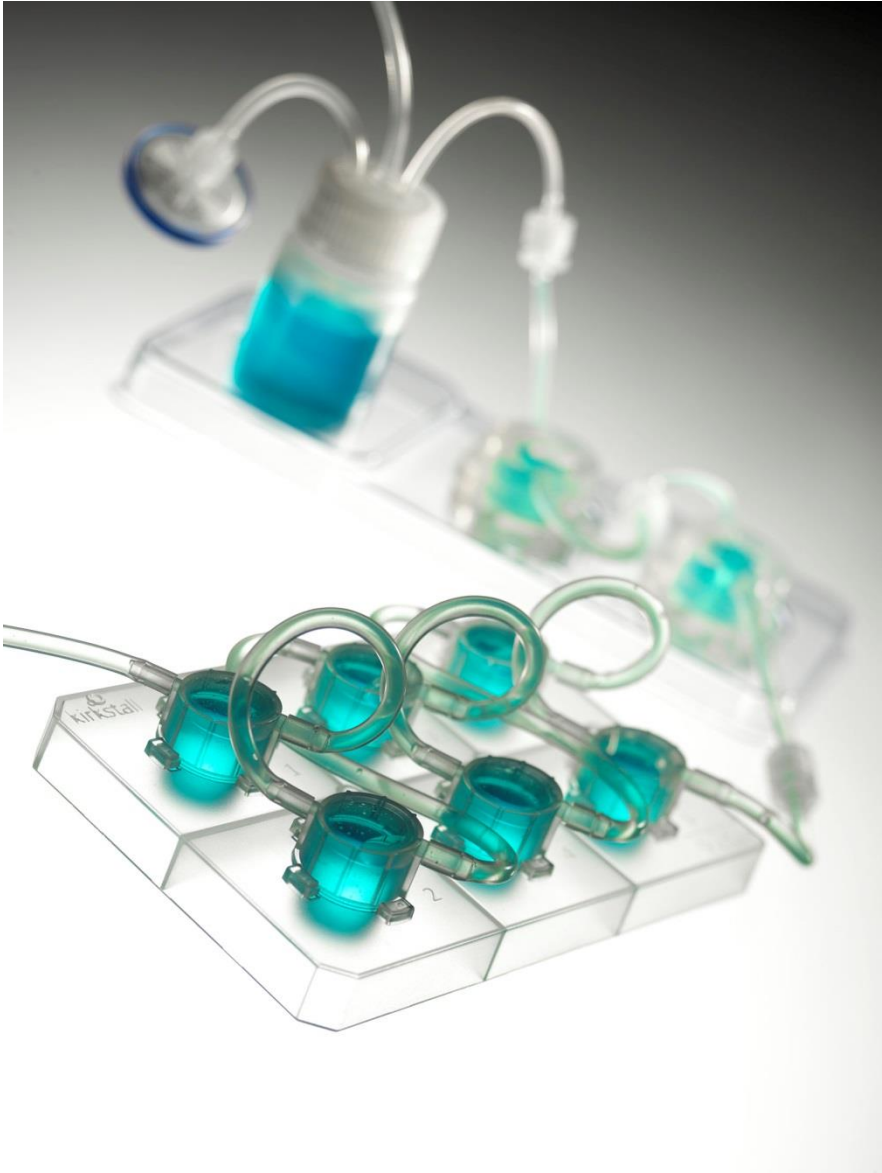

CONTENTS

1. QV900 Starter Kit.....	4
2. Setting up the QV900.....	5
3. During your Experiment.....	11
4. Ending the Experiment.....	12
5. FAQs.....	14
6. Reference Papers.....	15

This User manual is specific to the Quasi Vivo® QV500 cell culture system. It is aimed at scientists to enable the transition from static culture to perfusion culture techniques. We advise that you read this document thoroughly before starting an experiment. The methods described may be adapted to suit specific applications.

For further support, training courses demonstrating the assembly and use of the Quasi Vivo® cell culture system are available and you can contact the technical support team: info@kirkstall.com

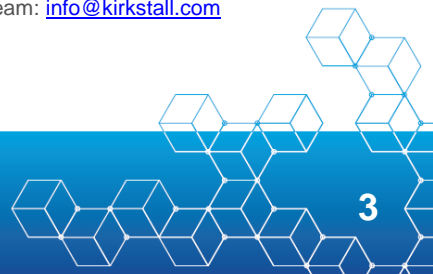

CONTENTS OF YOUR QV900 STARTER KIT

Your Quasi Vivo® system is delivered as a kit which includes:

- 3 QV900 trays with separately packaged lids
- Tool for fitting and removing chamber lids
- 3 packs of connecting tubings
- 2 reservoir bottles
- 6x 22 cm extension tubing in each of two diameters
- 6 each male and female luer connectors to fit each size of tubing
- A standard 0.2 µm filter

Spare tubing and connectors can be supplied, as well as additional items such as sampling ports; please contact info@kirkstall.com



Sterilisation

- QV900 trays are provided sterile and are single use only.
- Tubing, luer locks and the reservoir bottle should be autoclaved before first use (121 °C at 15 psi for 15 minutes).
- The filter is single use only, and should be replaced after each experiment.

How to connect the QV900

All steps should be done in a Class II biosafety hood, following standard sterile procedures.

1. Sterilise pump tubing (to be mounted on the pump rollers) by cleaning with 70% ethanol and then washing 3 times with PBS. Alternatively, this can be autoclaved.

NB Check the pump tubing for wear and tear before and during every experiment. Due to the nature of peristaltic pumps, this tubing will degrade over time due to the action of the rollers. We recommend that you replace the tubing for the Parker pumps (PF22X0103 and PF600) after 20 days of continual use.

2. The reservoir bottle has tubes of three different lengths:

- a) Short: with blue luer lock: the air filter should be attached here. This enables sterile gas exchange in the reservoir during the experiments and ensures that internal and external pressures are equalised.
- b) Medium: for the medium to return into the reservoir bottle. This is usually referred to as the return tubing.

- c) Long: for medium to be pulled from the reservoir bottle, into the circuit. This is the pump outflow tube.

3. Construct your Quasi Vivo® circuit, working around the circuit from the pump tubing in the direction of flow using the correct sized tubing, as indicated in Fig. 1.

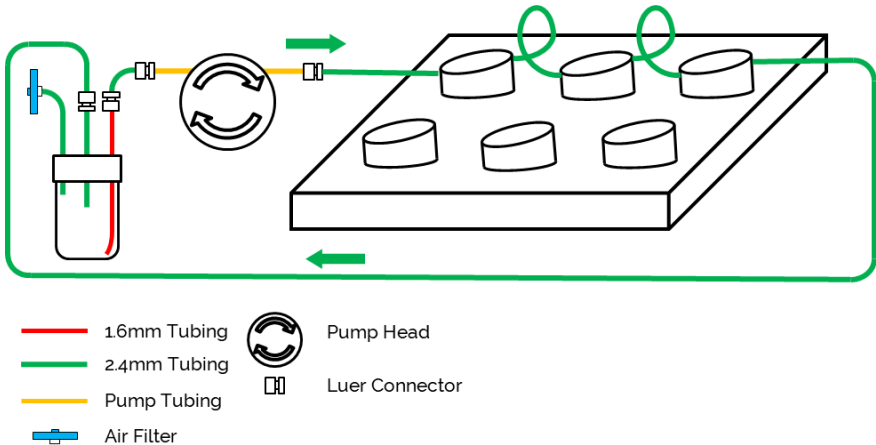

Figure 1. Example of the QV900 circuit with three chambers.

Some tubing will require the fitting of an appropriate luer lock; use the figure for guidance. Use the loading tray provided to hold the reservoir bottle and chambers in place.

- Connect a length of 2.4mm tubing to the end of the pump tube; either using a luer connector or by attaching the tubing directly to the connector fitted to the pump tubing.
- Connect this tubing to the inlet of the first chamber lid. Due to the size of the connector barbs the 2.4mm tubing should be used for all connections.
- Connect additional chamber lids using the shorter connecting tubing. The lids can be placed onto the tray to allow for easier setup, but the chambers should not be sealed at this stage if possible.

- d) Connect the outlet of the last chamber to the return tubing of the reservoir bottle (the medium length tube), using a length of the 2.4mm tubing.
- e) Connect the outlet tubing of the reservoir bottle (the longest one) to 1.6mm tubing using a luer lock and then back to the pump tubing to complete the circuit.

Pumps & Calibration

The Quasi Vivo® system uses a peristaltic pump to create flow. This pump design can generate low pressure, low velocity flow, which avoids causing stress or damage to the cells in the system. See below example flow rates.

Cell type	Flow rate (µl min ⁻¹)	Reference
Rat primary hepatocytes	180-500	Mazzei et al. 2010
Human primary hepatocytes	250-500	Vinci et al. 2011
hESC-derived hepatocytes	100-300	Rashidi et al. 2016
Oral and skin fibroblasts	75-150	Nithiananthan et al. 2016
Co-culture: Endothelial cells, hepatocytes and adipocytes	250	Vinci et al. 2012; Iori et al. 2012

Most such pumps have variable speed control, however the flow rate in the system will also vary depending on the number of chambers, the diameter and length of the tubing, the position of the chambers and reservoir in relation to the pump (for instance, placing on a higher shelf in the incubator) and, most importantly, on the type of pump used.

It is important to be aware of and control for these variables, which could influence your experiment, and so the system will need to be calibrated before use to ensure the flow rate is correct. Any subsequent modification to the system setup should be followed by recalibration.

Depending on the pump you choose to use, the calibration process will vary. Kirkstall supply a low cost dual-head pump produced by Parker Hannifin (model PF22x0103) specifically for use with the Quasi Vivo® system, however any peristaltic pump capable of supplying the required flow rates can be used. If your pump does not provide you with a readout of the actual flow rate, you will need to do the following to translate the pump speed to flow rate.

This process is required for the Parker pump. To calibrate the system:

1. Run the required configuration filled with sterile PBS and collect the liquid output over 5 minutes from the final chamber. It is important that air is expelled from the system before starting to measure the flow rate.
2. Measure the volume of liquid circulated by weighing the medium in a weighing boat after 5 minutes- remember to weigh the boat empty first.
3. Do this procedure three times for each of three different settings (for example, low, medium and high speed), then plot the mean values on a calibration curve, an example of which is shown in Fig. 2.

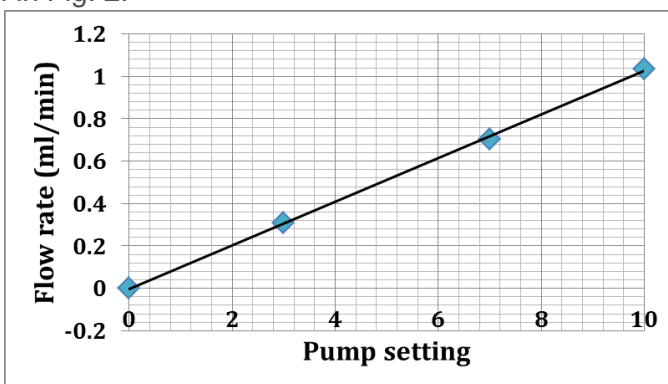

Figure 2. Example calibration curving using PF22X0103 with 3 QV500 chambers.

1. If you have followed the calibration scenario described in the previous section in aseptic conditions, you will have already washed the system. If not, the connected system should be washed by filling the reservoir bottle with sterile PBS and connecting the closed system to the peristaltic pump at maximum flow rate for at least 20 minutes.
2. The PBS can then be removed from the reservoir bottle. The PBS in the chambers and tubes should also be removed; this can be achieved by lifting the chambers above the reservoir to allow the liquid to return to the reservoir. This emptying procedure should never be used when cells are in the system.
3. The system should be primed with the culture medium to be used in the experiment, in the same manner as the PBS wash, and this medium then removed. The system is now ready to be used in an experiment.

Starting your experiment

1. Prepare cells as per normal experimental requirements. We recommend that cells are maintained under static conditions for some time before introducing flow to allow cells to. The time is dependent on cell type and experimental conditions - talk to one of our technical team for guidance. Cells can be seeded directly into the wells of the tray, or onto a coverslip/scaffold/gel in a static plate and transferred to the QV900.
2. Remove the lids (if pre-fitted) and transfer the prepared cells into each chamber.
3. Pipette 2 ml of cell culture medium into each chamber. This step is taken to reduce flow stress on the cells when the flow system starts, and also to avoid drying out.



4. Put the lids on the base, ensuring that the minimum amount of turning is required to close them. Place thumps on the lid, next to the inlet and the outlet, and press down. An audible click should be heard when closed correctly.

5. . The lid fitting tool slides over the two connecting barbs on the lids, and will fit with silicone tubing installed. The arrow on the tool should line up with the direction of flow, which will allow the tool to sit level. Turn the lid until it is fully closed.

6. Refit and seal the chamber lids, and ensure the circuit is fully sealed and that the connector tubing has no kinks or obstacles. It is a good idea to check that each luer lock has been secured tightly.

7. Add the required amount of medium to the reservoir bottle, taking into account the volume already added to each chamber.

8. Transfer the set-up to your incubator. Connect the pump tubing to the pump, set your pump speed and switch the pump on. Check the system after 10 minutes to ensure that fill up is complete.

9. If desired, control samples of cells can be kept in static conditions, either in static QV900 plates (with a length of tubing looped between the two connecting barbs) or in a standard cell culture plate.

DURING YOUR EXPERIMENT

Analysis

The QV900 chambers are compatible with a number of analysis techniques, including (but not limited to) Western Blotting, RT-PCR, microarray analyses, immunohistochemistry and viability assays such as the MTT assay. The simplest way to perform these assays is to remove your cells from the chamber and process them in the same way as you would for static culture. However, there is an increasing need for inline measurements, and these can be done in the QV900 by introducing sampling ports into the circuit; these contain a rubber septum through which a needle can be pushed to withdraw medium for analysis or inject into the system. Please contact the Kirkstall technical team for more information.

The QV900 has an optically clear base, which allows for imaging of cells seeded directly into the chamber. If your equipment allows, these can be imaged under flow, or the tray removed from the incubator and the circuit disconnected from the pump for imaging, and then the flow restarted upon return to the incubator.

Medium change

A change of the medium is generally necessary every 3-7 days. This depends on how many chambers you have connected to one reservoir bottle, the volume of medium in the reservoir bottle, and how metabolically active your cells are. We recommend that you replace half of the volume of your system during each change rather than the full amount, to ensure that conditioned medium is maintained.

Pump Maintenance

When using a peristaltic pump, the pump tubing is exposed to wear from the pump head. Check with the manufacturer of the pump tubing regarding how long you can run the pump and at what speed before the pump tubing starts to deteriorate. With the Parker pump (PF22X0103), the pump tubing should be changed after 20 days continuous use.

You should inspect the pump tubing and system when you perform medium change for signs of wear, such as the following: reduced transparency in the tubing, a rougher feel to the exterior of the tubing, cracking within the tubing, increased number of bubbles in the system.

ENDING YOUR EXPERIMENT

Disassembling the QV900

1. Reverse the direction of the flow (using the reverse flow switch if present, or by reversing the direction of the pump tubing around the rollers) and run the system until the tubing is empty; liquid will remain in the chambers, under the level of the outlet.
2. Stop the pump and detach the system by removing pump tubing from the rollers.
3. Move the system into the hood.
4. Detach the reservoir bottle from the circuit, but maintain sterility by connecting the two Luer locks together, creating a circuit without a reservoir.
5. Open the chamber lids.
6. Gently remove excess medium from the chamber, using a pipette.
7. If appropriate, remove the cells from the tray and place them into your chosen assay receptacle, eg a standard cell culture plate. Coverslips and 3D scaffolds can be removed using forceps, whilst 3D gels should be removed according to the gel manufacturer's instructions. Assays can also be conducted in the QV900, if cells are seeded directly into the chamber wells.
8. Follow the manufacturer's instructions for your chosen assay. For example, this could be an MTT assay or immunohistochemical staining; remember to perform the same assay for your static controls.

Cleaning the QV900

The QV900 tray is single use only and should be disposed of after use according to laboratory protocols.

There are two methods to sterilise the tubing, connectors, and reservoir bottle.

Procedure A: Tubing, connectors, and reservoir bottles can be stored after opening for longer periods of time. In this case, tubing and connectors should be stored submerged in 70% ethanol. Reservoir bottles should be rinsed with 70% ethanol followed by sterile PBS (long exposure to ethanol can damage the surface of silicone chambers), emptied and stored until needed. Used air filters on reservoir bottles should be discarded.

Procedure B: Silicone parts, as well as reservoir bottles, can be sterilised using standard autoclaving procedure (121°C, 15 psi, 15 minutes).

However, to maintain reliability of the system we advise not to exceed more than 3 sterilisation cycles for any component. The translucent polypropylene luer lock connectors supplied with the kit are also autoclave safe.

We advise NOT TO wash with sodium azide which can accumulate on the surfaces of chambers and leak out during the experiment.

1. Why has an air bubble entered the system?

If this occurs as the system is filling up, this is normal and any bubbles will be removed by the slant in the roof of the chamber. Ensure the chamber is connected the correct way round; thin tube at the inlet, thick tube at the outlet. Bubbles will be removed from the system when they enter the reservoir. If bubbles are persistent, check the pump tubing for wear.

2. Why is the system leaking?

This should not happen in normal operation. Check all the connections between tubes and ensure the chambers are correctly assembled. Check the tubing for breaks due to fatigue. Opening and closing the system can also cause leakage; try to minimise this during your experiment.

3. Can you reuse the system?

QV900 trays are single use only. The reservoir bottle, tubing and luer lock components can be autoclaved repeatedly.

4. Is the medium recirculating or single pass?

The system is designed to use recirculating medium, which allows cells to condition the medium with growth factors and signaling molecules, and therefore improves growth, viability, and the system's ability to model the *in vivo* environment. However, it can easily be set up to allow single pass.

5. How many chambers can be connected to the same reservoir bottle?

In a recirculating system, up to 6 chambers can be connected to a single 30 ml reservoir bottle. Larger or smaller bottles will support different numbers of chambers.

6. How long can cells be cultured for?

Hepatocytes have been cultured for a month and retained their phenotype and CYP gene expression. The length of the experiment can be varied from 1 to 3 day experiments, to week or month-long studies and potentially longer.

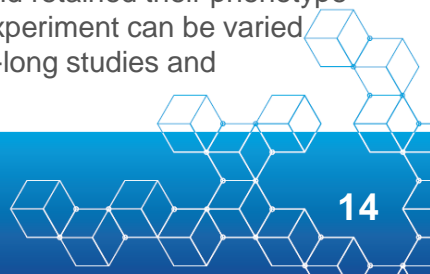

Iori, E. et al., 2012. Glucose and fatty acid metabolism in a 3 tissue in-vitro model challenged with normo- and hyperglycaemia. PLoS ONE, 7(4), pp.1–9.

Mattei, G., Giusti, S. & Ahluwalia, A., 2014. Design Criteria for Generating Physiologically Relevant In Vitro Models in Bioreactors. Processes, 2, pp.548–569.

Mazzei, D. et al., 2010. A low shear stress modular bioreactor for connected cell culture under high flow rates. Biotechnology and Bioengineering, 106, pp.127–137.

Nithianathan, S. et al., 2016. Physiological Fluid Flow Moderates Fibroblast Responses to TGF- β 1. Journal of cellular biochemistry, 13(October), pp.1–13.

Ramachandran, S.D. et al., 2015. In vitro generation of functional liver organoid-like structures using adult human cells. PLoS ONE, 10(10), pp.1–14.

Rashidi, H. et al., 2016. Fluid shear stress modulation of hepatocyte-like cell function. Archives of Toxicology, pp.3–7.

Vinci, B. et al., 2012. An in vitro model of glucose and lipid metabolism in a multicompartmental bioreactor. Biotechnology Journal, 7, pp.117–126.

Vinci, B. et al., 2011. Modular bioreactor for primary human hepatocyte culture: Medium flow stimulates expression and activity of detoxification genes. Biotechnology Journal, 6, pp.554–564.

Chandorkar, P. et al., 2017. Fast-track development of an *in vitro* 3D lung / immune cell model to study Aspergillus infections. Scientific reports, 7(February), p.11644.

**For a fully up-to-date list, please see our
website: www.kirkstall.com**

QV 900

